

Biotechnology Principles & Processes

1. Lactobacillus that sets milk into curd is categorised as : (2024)

- (A) Cyanobacteria
- (B) Archaeobacteria
- (C) Chemosynthetic bacteria
- (D) Heterotrophic bacteria

Ans. (D) Heterotrophic bacteria

2. Case-based questions. Each question has 3 sub-questions with internal choice in one sub-question. (2024)

Study the diagram given below that shows the steps involved in the procedure of selecting transformed bacteria and answer the questions that follow :

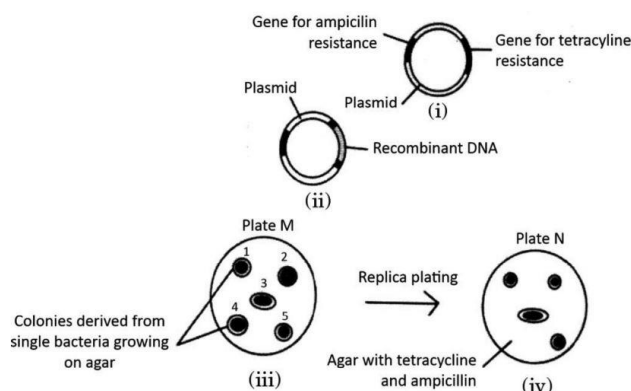

(a) Identify the colony that has got transformed. Justify your answer.

Ans. Colony 4 is transformed with plasmid containing recombinant DNA, as they will not show resistance towards tetracycline.

(b) What are the sites in a plasmid called where ampicillin and tetracycline resistance genes are inserted? State their role in genetic engineering.

Ans. Award 2 marks to each student .

(c) Name two enzymes playing an important role in genetic engineering.

Ans. Restriction endonuclease / ligase / Taq DNA Polymerase

OR

(c) State the role of β -galactosidase in insertional inactivation.

Ans. Insertional inactivation of gene encoding for β -galactosidase will lead to colorless bacterial colonies (recombinant)

Previous Years' CBSE Board Questions

9.1 Principles of Biotechnology

MCQ

1. In biotechnology experiments, 'molecular scissors' used are

- (a) plasmid (b) restriction enzymes
(c) vectors (d) sigma factor. (2020C)

VSA (1 mark)

2. What is the cell that receives a recombinant gene called?
(AI 2019)

3. Write the two components of the first artificial recombinant DNA molecule constructed by Cohen and Boyer. (Foreign 2014)

9.2 Tools of Recombinant DNA Technology

MCQ

4. Given below is the restriction site of a restriction endonuclease Pst-I and the cleavage sites on a DNA molecule.

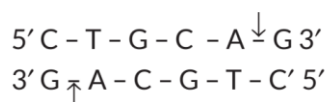

Choose the option that gives the correct resultant fragments by the action of the enzyme Pst-I.

- (a) $\begin{array}{l} 5' \text{ C - T - G} \qquad \qquad \text{C - A - G } 3' \\ 3' \text{ G - A - C - G - T} \qquad \qquad \text{C } 5' \end{array}$
(b) $\begin{array}{l} 5' \text{ C - T} \qquad \qquad \text{G - C - A - G } 3' \\ 3' \text{ G - A - G - C} \qquad \qquad \text{T - C } 5' \end{array}$
(c) $\begin{array}{l} 5' \text{ C - T - G - C} \qquad \text{A - G } 3' \\ 3' \text{ G - A - C - G} \qquad \text{T - C } 5' \end{array}$
(d) $\begin{array}{l} 5' \text{ C - T - G - C - A} \qquad \qquad \qquad \text{G } 3' \\ 3' \text{ G} \qquad \qquad \qquad \text{A - C - G - T - C } 5' \end{array}$

(2023)

5. Introduction of an alien DNA into a plant host cell is achieved by making them

- (a) competent with bivalent ions
(b) using microinjections
(c) using gene gun



(d) using lysozymes and chitinase. (2020)

VSA (1 mark)

6. A host cell must be made competent, before it is able to receive an rDNA. Justify. (1/3 Term II, 2021-22)

7. Suggest a technique to a researcher who needs to separate fragments of DNA. (Delhi 2016)

8. Mention the type of host cells suitable for the gene gun to introduce an alien DNA. (Delhi 2014)

9. Name the host cells in which microinjection technique is used to introduce an alien DNA. (Foreign 2014)

10. Name the material used as matrix in gel-electrophoresis and mention its role. (AI 2014C)

SA I (2 marks)

11. 'Insertional inactivation' is a method to detect recombinant DNA. Explain the method. (2023)

12. How does EcoRI specifically act on DNA molecule? Explain. (2020)

13. Write the basis of naming the restriction endonuclease EcoRI. (2020)

14. All cloning vectors do have a 'selectable marker' Describe its role in recombinant DNA technology. (2020)

15. B-galactosidase enzyme is considered a better selectable marker. Justify the statement. (Delhi 2019)

16. Explain the principle that helps in separation of DNA fragments in Gel electrophoresis. (2019C)

17. What is EcoRI? How does EcoRI differ from an exonuclease? (Delhi 2015C)

18. State how has *Agrobacterium tumefaciens* been made a useful cloning vector to transfer DNA to plant cells. (Delhi 2014)

19. How are 'sticky ends' formed on a DNA strand? Why are they so called?

(Delhi 2014)

20. Write the role of ori and 'restriction' site in a cloning vector pBR322. (Delhi 2014)



21. How does a restriction nuclease function? Explain.

(AI 2014)

22. How is insertional inactivation of an enzyme used as a selectable marker to differentiate recombinants from non-recombinants?

(Foreign 2014)

23. Explain palindromic nucleotide sequence with the help of a suitable example.

(Foreign 2014)

24. Why is making cells competent essential for biotechnology experiments? List any two ways by which this can be achieved.

(AI 2014C)

SA II (3 marks)

25. (a) Given below is the stepwise schematic representation of the process of electrophoresis. Identify the 'alphabets' representing (i) Anode end (ii) smallest/lightest DNA strand in the matrix (iii) Agarose gel

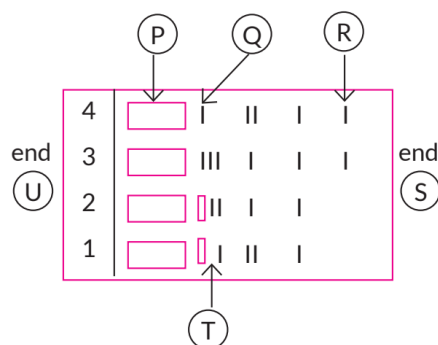

(b) What is elution? State the importance of elution in this process.

(Term II, 2021-22)

26. Non-viral and non-vector methods are sometimes used to transfer genes or alien DNA into a plant cell. Explain one such method used in genetic engineering.

(Term II, 2021-22)

27. Name any two natural cloning vectors. Give reasons that make them act as cloning vectors. Write the two characteristics the engineered vectors are made to possess.

(2020)

28. (a) Write the palindromic nucleotide sequence EcoRI recognises.

(b) Draw the vector DNA and a foreign DNA showing the sites where EcoRI has acted to form the sticky ends.

(c) Name the enzymes that help in forming recombinant DNA.
(2020)

29. Given below is the diagram representing the observations made for separating DNA fragments by gel electrophoresis technique. Observe the illustration and answer the questions that follow:

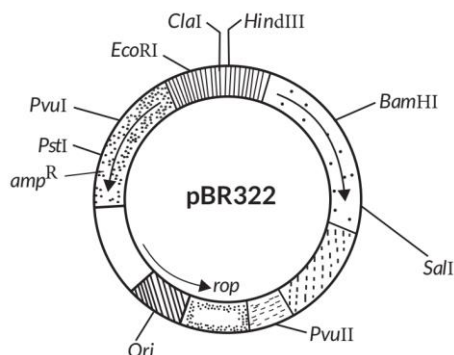

- (a) Why are the DNA fragments seen to be moving in the direction A → B?
- (b) Write the medium used in which DNA fragments separate.
- (c) Mention how the separated DNA fragments can be visualised for further technical use.

(2020)

30. Observe the diagram shown below of pBR322. Answer the questions that follow:

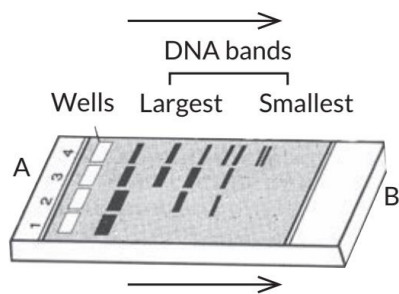

- (a) What is pBR322?
- (b) Write the role of 'rop'.
- (c) State the significance of amp^R and tet^R.
(2020)

31. Describe the formation of recombinant DNA by the action of EcoRI.
(Delhi 2019)

32. How does β-galactosidase coding sequence act as a selectable marker? Why is it a preferred selectable marker to antibiotic resistance genes? Explain.
(AI 2019)

33. Explain the roles of the following with the help of an example each, in recombinant DNA technology:

(a) Restriction enzymes

(b) Plasmids

(2018)

34. Explain the roles of the following in biotechnology:

(a) Restriction endonuclease

(b) Gel-electrophoresis

(c) Selectable markers in pBR322.

(Delhi 2017)

35. (a) Explain the significance of 'palindromic nucleotide sequence' in the formation of recombinant DNA.

(b) Write the use of restriction endonuclease in the above process.

(AI 2017)

36. (a) Name the selectable markers in the cloning vector pBR322. Mention the role they play.

(b) Why is the coding sequence of an enzyme β -galactosidase a preferred selectable marker in comparison to the ones named above?

(AI 2016)

37. (a) Why must a cell be made 'competent' in biotechnology experiments? How does calcium ion help in doing so?

(b) State the role of 'biolistic gun' in biotechnology experiments.

(AI 2016)

38. Name and describe the technique that helps in separating the DNA fragments formed by the use of restriction endonuclease.

(Foreign 2015, AI 2014)

39. State the functions of the following in the cloning vector pBR322:

(a) ori,

(b) rop, and

(c) HindIII sites

(AI 2015C)



40. Draw pBR322 cloning vector. Label 'ori', 'rop' and any one antibiotic resistance site on it and state their functions.

(NCERT Exemplar, AI 2015C)

41. Draw a schematic diagram of the E. coli cloning vector pBR322 and mark the following in it:

(a) ori

(b) rop

(c) ampicillin resistance gene

(d) tetracycline resistance gene

(e) restriction site BamHI

(f) restriction site EcoRI

(AI 2014C)

42. (a) Draw schematic diagrams of segments of a vector and a foreign DNA with the sequence of nucleotides recognised by EcoRI.

(b) Draw the vector DNA segment and foreign DNA segments after the action of EcoRI and label the sticky end produced.

(AI 2014C)

LA (5 marks)

43. (i) 'EcoRI' has played very significant role in r-DNA technology.

(I) Explain the convention for naming EcoRI.

(II) Write the recognition site and the cleavage sites of this restriction endonuclease.

(ii) What is the protruding and hanging stretches of DNA produced by these restriction enzymes called? Describe their role in formation of r-DNA.

(2023)

44. (a) Answer the following questions with respect to recombinant DNA technology:

(i) Why is plasmid considered to be an important tool in rDNA technology? From where can plasmids be isolated?

(Any two sources)

(ii) Explain the role of 'ori' and selectable marker in a cloning vector.

(iii) "r-DNA technology cannot proceed without restriction endonuclease." Justify.

(2023)



45. (a) Restriction endonucleases are a class of bacterial enzymes that recognize a specific short sequence of nucleotides within a double-stranded DNA molecule. The natural purpose of these enzymes is to protect bacteria from pathogens, notably bacteriophages. There are different classes of restriction enzymes, but type-II restriction enzymes are widely used in manipulating DNA as they recognise short sequence nucleotides that are typically palindromes.

(i) Name a specific restriction endonuclease and write the palindromic nucleotide sequence in the DNA recognised by this enzyme. Also, indicate the site at which it makes the cut.

(ii) A piece of DNA is cut by a restriction enzyme. The fragments are then separated by gel electrophoresis and stained by ethidium bromide. Write the principle on which gel electrophoresis works.

(Term II, 2021-22C)

46. Gene of interest/alien gene is introduced by a cloning vector into a host cell to bring about a desired phenotypic expression in a host cell. The cloning vectors used are plasmid and bacteriophages. Biotechnologists in their labs, for desired results engineered specialised cloning vectors. One such vector is pBR322. Study the diagram carefully and answer the questions that follows.

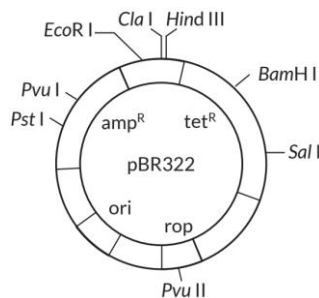

(i) What do 'EcoRI', 'BamHI' and 'Hind III' represent? State their functions.

(ii) Identify the gene you would select for the role of a selectable marker in pBR322. Explain why.

(iii) Write the property/characteristic of plasmid and bacteriophage that makes them efficient cloning vectors.

(iv) Biotechnologists always insert 'ori' gene in their engineered cloning vector. Justify the statement.

(v) Will the experiment be successful if the alien DNA is ligated at Hind III restriction site? Give reason in support of your answer.

(Term II, 2021-22)

47. Cloning of genes, play a very significant role in genetic engineering, helping the transfer of desirable foreign genes into different hosts. The scientists, to make

this process easier and effective are creating engineered vectors in such a way that they help easy linking of foreign DNA and selection of recombinants from non-recombinants. 'pBR322' is one such engineered vectors developed by scientists. A diagram of an engineered vector pBR322 is given below:

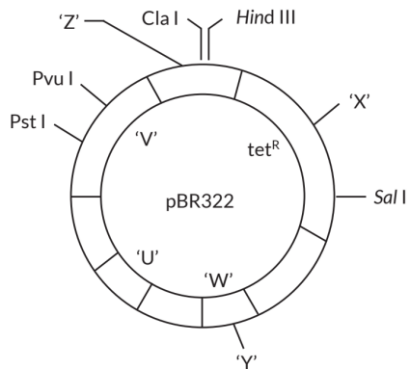

- (i) Name the host for this cloning vector.
- (ii) Identify 'rop' and 'ori' in the diagram from 'U', 'V' 'W' 'X' 'Y' and 'Z'. Write their functions.
- (iii) Draw the fragments that will be formed by the action of 'Z' (marked in the diagram) on the specific site of the DNA segment given below.

5' --- GTACGAATTCCTGA --- 3'
3' --- GTAGCTTAAGGACT --- 5'

(Term II, 2021-22)

48. Unless the vector and source DNA are cut, fragments separated and joined, the desired recombinant vector molecule cannot be created.

- (a) How are the desirable DNA sequences cut?
 - (b) Explain the technique used to separate the cut fragments.
 - (c) How are the resultant fragments joined to the vector DNA molecule?
- (Delhi 2015C)

9.3 Processes of Recombinant DNA Technology

MCQ

49. Assertion (A): Synthetic oligo-nucleotide polymers are used during annealing in a PCR.

Reason (R): The primers bind to the double stranded DNA at their complementary regions.

- (a) Both (A) and (R) are true and (R) is the correct explanation of (A).
- (b) Both (A) and (R) true, but (R) is not the correct explanation of (A).

(c) (A) is true, but (R) is false.

(d) (A) is false, but (R) is true.

(2023)

50. The given schematic illustration shows three steps 'P', 'Q' and 'R' of the polymerase chain reaction.

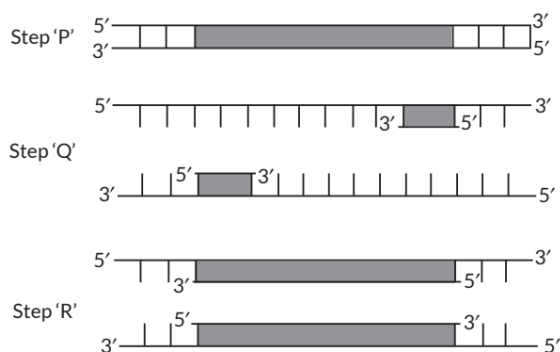

Which of the following statements are correct with reference to the illustration given above?

(i) Step 'P' is showing denaturation at low temperature.

(ii) Step 'Q' is a denaturation of DNA strand at high temperature, followed by annealing.

(iii) Step 'R' is an extension of DNA in presence of thermostable DNA polymerase.

(iv) Step 'Q' is extension with two sets of primers.

(a) (i) and (iii) only

(b) (ii) and (iii) only

(c) (ii) only

(d) (i) only

(2023)

VSA (1 mark)

51. Name the enzymes that are used for the isolation of DNA from bacterial and fungal cells for recombinant DNA technology.

(AI 2014, Foreign 2014)

SA I (2 marks)

52. (a) Write the scientific name of the source organism of the thermostable DNA polymerase used in PCR.

(b) State the advantage of using thermostable DNA polymerase.

(2023)

53. Why is Taq polymerase preferred in PCR? Mention the source of this enzyme.

(Delhi 2015C)

SA II (3 marks)

54. (a) Simple stirred-tank bioreactors are used to produce large quantities of recombinant proteins, stirring the contents and mixing it with oxygen. Write any four other advantages of using stirred tank.

(b) After downstream processing, the product of the biosynthetic stage cannot be marketed directly. Why? Give two reasons.

(Term II, 2021-22C)

55. Causative agents of HIV-AIDS and COVID-19 belong to the same group of viruses. To diagnose and amplify the genetic material for further study of COVID-19 virus, 'RT-PCR' test is carried out.

(a) What does 'RT-PCR' stand for?

(b) Explain the various steps of PCR technique.

(Term II, 2021-22)

56. A cell free method of amplifying DNA first developed in the mid 1980's revolutionised the field of biotechnology. Name the method and explain the basic steps of the technique involved.

(Term II, 2021-22)

57. Describe the process of amplification of "gene of interest" using PCR technique.

(2019 C, Delhi 2019)

OR

Many copies of a specific gene of interest are required to study the detailed sequencing of bases in it. Name and explain the process that can help in developing large number of copies of this gene of interest.

(Foreign 2015)

58. Give reasons why:

(a) DNA cannot pass into a host cell through the cell membrane.

(b) Proteases are added during isolation of DNA for genetic engineering.

(c) Single cloning site is preferred in a vector.

(AI 2019)

59. (a) Name the most commonly used bioreactor. Why are these bioreactors used?

(b) How is the operation in a bioreactor carried out so as to achieve the desired end product?



(2019 C)

60. Describe the roles of (a) high temperature, (b) primers and (c) bacterium *Thermus aquaticus* in carrying the process of polymerase chain reaction.

(AI 2019)

OR

Describe the roles of heat, primers and the bacterium *Thermus aquaticus* in the process of PCR.

(AI 2017)

61. (a) How has the development of bioreactor helped in biotechnology?

(b) Name the most commonly used bioreactor and describe its working.

(2018)

62. Write the steps you would suggest to be undertaken to obtain a foreign-gene-product.

(Delhi 2017)

63. Rearrange the following in the correct sequence to accomplish an important biotechnological reaction:

(i) Denaturation of dsDNA

(ii) Chemically synthesised oligonucleotides

(iii) Primers

(iv) Complementary region of DNA

(v) Thermostable DNA polymerase (from *Thermus aquaticus*)

(vi) Nucleotides provided

(vii) Genomic DNA template

(viii) In vitro synthesis of copies of DNA of interest

(ix) Enzyme DNA polymerase.

(AI 2015)

64. Prepare a flow chart in formation of recombinant DNA by the action of restriction endonuclease enzyme EcoRI.

(Foreign 2015)

65. (a) List the three steps involved in Polymerase Chain Reaction (PCR).

(b) Name the source organism of Taq polymerase. Explain the specific role of this enzyme in PCR.



(Foreign 2014)

66. What is a bioreactor used for? Name a commonly used bioreactor and any two of its components.

(Delhi 2014C)

67. (a) What is a bioreactor? How does it work?

(b) Name two commonly used bioreactors.

(Delhi 2014C)

LA (5 marks)

68. Bioreactors are the containment vehicles of any biotechnology-based production process. For large scale production and for economic reasons the final success of biotechnological process depends on the efficiency of the bioreactor.

Answer the following questions with respect to the given paragraph.

(i) List the operational guidelines that must be adhered to so as to achieve optimisation of the bioreactor system. Enlist any four.

(ii) Mention the phase of the growth we refer to in the statement "Optimisation of growth and metabolic activity of the cells".

(iii) Is the biological product formed in the bioreactor suitable for the intended use immediate? Give reason in support of your answer.

(2023)

69. (a) Explain the different steps carried out in polymerase chain reaction and the specific roles of the enzymes used.

(b) Mention application of PCR in the field of

(i) Biotechnology

(ii) Diagnostics.

(2020)

70. (a) Describe the different steps in one complete cycle of PCR.

(b) State the purpose of such an amplified DNA sequence.

(AI 2015C)



CBSE Sample Questions

9.2 Tools of Recombinant DNA Technology

MCQ

1. The given figure shows the structure of a plasmid.

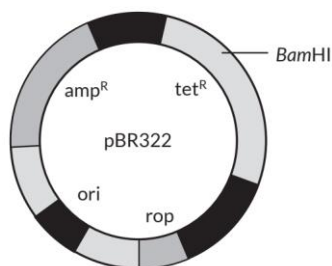

A foreign DNA was ligated at BamHI. The transformants were then grown in a medium containing antibiotics tetracycline and ampicillin. Choose the correct observation for the growth of bacterial colonies from the given table.

	Medium with tetracycline	Medium with ampicillin
(a)	Growth	No growth
(b)	No growth	Growth
(c)	No growth	No growth
(d)	Growth	Growth

(2022-2023)

2. Assertion: *E. coli* having pBR322 with DNA insert at BamHI site cannot grow in medium containing tetracycline.

Reason: Recognition site for Bam HI is present in tetR region of pBR322.

(a) Both assertion and reason are true, and reason is the correct explanation of assertion.

(b) Both assertion and reason are true, but reason is not the correct explanation of assertion.

(c) Assertion is true but reason is false.

(d) Both assertion and reason are false.

(2020-21)

VSA (1 mark)

3. Name the commonly used vector for cloning genes into higher organisms.

(2020-21)



SA I (2 marks)

4. CTTAAG

GAATTC

(a) What are such sequences called? Name the enzyme used that recognises such nucleotide sequences.

(b) What is their significance in biotechnology?

(2022-23)

5. Explain the method to increase the competency of the bacterial cell membrane to take up recombinant DNA.

(2020-21)

6. What are sticky ends? State their significance in recombination DNA technology. (2020-21)

SA II (3 marks)

7. Carefully observe the given picture. A mixture of DNA with fragments ranging from 200 base pairs to 2500 base pairs was electrophoresed on agarose gel with the following arrangement.

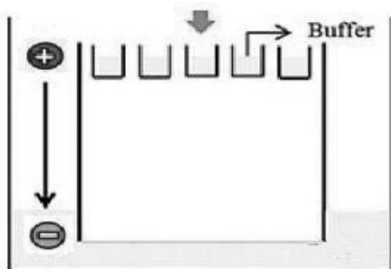

(a) What result will be obtained on staining with ethidium bromide? Explain with reason.

(b) The above set-up was modified and a band with 250 base pairs was obtained at X.

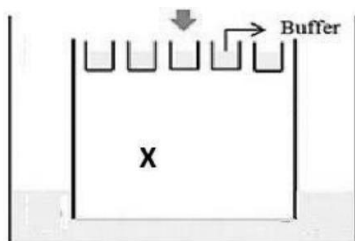

What change(s) were made to the previous design to obtain a band at X? Why did the band appear at the position X?

(2022-23)



8. The image below depicts the result of gel electrophoresis.

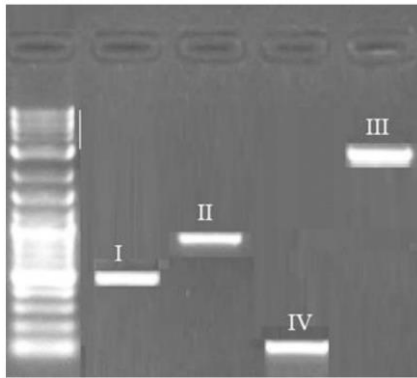

If the ladder represents sequence length upto 3000 base pairs (bp),

- (a) Which of the bands (I - IV) correspond to 2500 bp and 100 bp respectively?
- (b) Explain the basis of this kind of separation and also mention the significance of this process.

(Term II, 2021-22)

LA (5 marks)

9. Some restriction enzymes break a phosphodiester bond on both the DNA strands, such that only one end of each molecule is cut and these ends have regions of single stranded DNA. BamHI is one such restriction enzyme which binds at the recognition sequence, 5'-GGATCC-3' and cleaves these sequences just after the 5'- guanine on each strand.

- (a) What is the objective of this action?
- (b) Explain how the gene of interest is introduced into a vector.
- (c) You are given the DNA shown below.

5' ATTTTGAGGATCCGTAATGTCCT 3'

3' TAAAACTCCTAGGCATTACAGGA 5'

If this DNA was cut with BamHI, how many DNA fragments would you expect? Write the sequence of these double-stranded DNA fragments with their respective polarity.

(d) A gene M was introduced into E.coli cloning vector pBR322 at BamHI site. What will be its impact on the recombinant plasmids? Give a possible way by which you could differentiate non-recombinant to recombinant plasmids.

(Term II, 2021-22)

9.3 Processes of Recombinant DNA Technology

SA I (2 marks)

10. What are bioreactors? How are large volumes of cultures maintained and processed in them?

(2020-21)

11. Explain the role of enzymes in the extraction of DNA from *Rhizopus* in its purest form. (2020-21)

12. Explain the procedure by which PCR aids in early detection of cancer. (2020-21)

SA II (3 marks)

13. In a pathological lab, a series of steps were undertaken for finding the gene of interest. Describe the steps, or make a flow chart showing the process of amplification of this gene of interest.

(Term II, 2021-22)

LA (5 marks)

14. Oil spill is a major environmental issue. It has been found that different strains of *Pseudomonas* bacteria have genes to break down the four major groups of hydrocarbons in oil. Trials are underway to use different biotechnological tools to incorporate these genes and create a genetically engineered strain of *Pseudomonas*- a 'super-bug, to break down the four major groups of hydrocarbons in oil. Such bacteria might be sprayed onto surfaces polluted with oil to clean thin films of oil.

(a) List two advantages of using bacteria for such biotechnological studies.

(b) For amplification of the gene of interest PCR was carried out. The PCR was run with the help of polymerase which was functional only at a very low temperature. How will this impact the efficiency of the PCR? Justify.

(c) If such bacteria are sprayed on water bodies with oil spills, how will this have a positive or negative effect on the environment? Discuss.

(2022-23)



Detailed SOLUTIONS

Previous Years' CBSE Board Questions

1. (b): Restriction enzymes are also called 'molecular scissors' as they cleave DNA at or near specific recognition sequences known as restriction sites.
2. The cell that receives recombinant gene is known as genetically modified cell or recombinant cell.
3. Two components of first artificial recombinant DNA molecule constructed are :
An antibiotic resistance gene and plasmid of *Salmonella typhimurium*.
4. (d)
5. (a): DNA is a hydrophilic molecule, it cannot pass through membranes, so cells must be made capable to take up DNA. This is done by treating them with a specific concentration of a divalent cation such as calcium which increases the efficiency with which DNA enters the bacterium through pores in its cell wall.
6. DNA is a hydrophilic molecule, it cannot pass through membranes, so the host cells must be made capable to take up the DNA. This is done by treating them with a specific concentration of a divalent cation, such as calcium followed by heat shock treatment.
7. Separation of DNA fragments can be done by a technique called agarose gel electrophoresis. In this technique, the DNA molecules are separated according to their size, under the influence of an electric field (DNA being negatively charged moves from cathode to anode).
8. Undifferentiated plant cells are the most suitable host cells for the gene gun to introduce an alien DNA. It is because plant cells have rigid cell wall which can be easily broken down by bombarding them with high velocity micro-particles of gold or tungsten coated with DNA.
9. Microinjection technique is used to introduce an alien DNA directly into the nucleus of the animal host cells such as oocytes, eggs and embryo.
10. Most commonly used matrix in DNA gel electrophoresis is agarose. It provides sieving effect for separation of DNA fragments according to their size.
11. Insertional inactivation refers to the process where insertion of rDNA within the coding sequence of an enzyme causes its inactivation. The non-recombinants having intact functional gene, e.g., β -galactosidase produce blue colour with chromogenic substrate but when rDNA is inserted within the coding sequence of enzyme β -galactosidase, recombinants do not produce any colour. Hence,



recombinants can be easily differentiated from non-recombinants due to insertional inactivation.

12. EcoRI is a type II restriction endonuclease enzyme which recognises the base sequence at palindrome sites in DNA duplex and cut its strand. It recognises the base sequence GAATTC in DNA duplex and cut its strands between G and A as shown below:

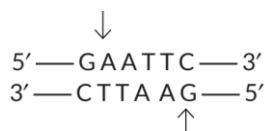

The product obtained is as follows:



13. Type II restriction enzymes are named for the bacterium from which they have been isolated. The first letter used for the enzyme is the first letter of the bacterium's genus (in italics). Then comes the first two letters of the species (in italics). EcoRI is obtained from bacterium *Escherichia coli* RY13. The capital letter E comes from genus *Escherichia*. The letters co are from species *coli*. The letter R is from RY13 (strain). The roman number I indicates that it was the first enzyme isolated from bacterium *E.coli* RY13.

14. Selectable markers are the gene sequence present in cloning vectors that help in selecting those host cells which contain vectors (transformants) and eliminating the non-transformants. Generally, the genes encoding resistance to antibiotics such as tetracycline, ampicillin, kanamycin or chloramphenicol are useful selectable markers for *E.coli*. Plasmid pBR322 has two resistance genes - ampicillin resistance (amp^R) and tetracycline resistance (tet^R) which are considered useful for selectable markers.

15. The gene for the enzyme β -galactosidase is an alternative selectable marker. Alternative selectable marker is developed to differentiate recombinants and non-recombinants on the basis of their ability to produce colour in the presence of a chromogenic substance. Now a recombinant DNA is inserted in the coding sequence of an enzyme β -galactosidase. Presence of insert results into insertional inactivation of the β -galactosidase and therefore the colonies do not produce any colour and are marked as recombinant colonies. Hence, β -galactosidase enzyme is considered a better selectable marker.

16. After the cutting of DNA by restriction enzyme, fragments of DNA are formed. Separation of DNA fragments according to their size or length is done by a technique called agarose gel electrophoresis. It is a technique of separation of molecules such as DNA, RNA or protein, under the influence of an electrical field,



so that they migrate in the direction of electrode bearing the opposite charge, viz., positively charged molecules move towards cathode (-ve electrode) and negatively charged molecules travel towards anode (+ve electrode) through a medium/matrix. Most commonly used matrix is agarose. DNA fragments separate according to their size through the pores of agarose gel. Hence smaller the fragment size, the farther it moves.

17. EcoRI is a restriction endonuclease enzyme. It recognises base sequences 5'-GAATTC-3' in DNA duplex 3'-CTTAAG-5' and cuts each of the two strands between G and A. On the other hand, exonuclease remove nucleotide from the terminal ends of DNA in one strand of duplex.

Hence, EcoRI cut each of the two strand of DNA duplex at specific point whereas exonuclease remove nucleotide from the terminal ends (either 5' or 3') of DNA in one strand of duplex.

18. *Agrobacterium tumefaciens* is a soil-inhabiting bacterium that may invade growing plants at the junction of root and stem, where it can cause a cancerous growth known as a crown gall. *A. tumefaciens* contains Ti plasmid which carries gene for tumour formation. For using *Agrobacterium tumefaciens* as a cloning vector researchers deleted the genes which governs auxin and cytokinin production (the oncogene) from T-DNA of Ti plasmid.

It is known as disarming. After disarming, this T-DNA is inserted into chromosomes of the host plant where it produces copies of itself.

19. When restriction enzymes cut the strand of DNA a little away from the centre of the palindromic sites, between the same two bases on the opposite strands, it leaves single stranded portions at the ends. These forms overhanging stretches called sticky ends on each strand.

They are called sticky as they form hydrogen bonds with their complementary cut counterparts. The stickiness of the ends facilitates the action of the enzyme DNA ligase.

20. Origin of replication (ori) site in cloning vector pBR322 is a sequence from where replication starts. Any piece of DNA when linked to this sequence can be made to replicate within host cell. Restriction site within the markers tet^R and amp^R genes permit an easy selection for cells transformed with the recombinant pBR322.

21. Restriction nucleases act as molecular scissors or chemical scalpels. Each restriction endonuclease functions by 'inspecting' the length of a DNA sequence. Once it finds its specific recognition sequence, it will bind to the DNA and cut each of the two strands of the double helix at specific points in their sugar-

phosphate backbones. Each restriction endonuclease recognises a specific palindromic nucleotide sequence in the DNA.

22. Insertional inactivation refers to the process where insertion of rDNA within the coding sequence of an enzyme causes its inactivation.

The non-recombinants having intact functional gene, e.g., β -galactosidase produce blue colour with chromogenic substrate but when rDNA is inserted within the coding sequence of enzyme β -galactosidase, recombinants do not produce any colour.

Hence, recombinants can be easily differentiated from non-recombinants due to insertional inactivation.

23. The palindrome sequence in DNA is a sequence of base pairs that reads same on the two strands when orientation of reading is kept the same.

For example, the following sequence reads the same on the two strands in 5' \rightarrow 3' direction. This is also true if read in the 3' \rightarrow 5' direction.

5'-GAATTC-3'

3'-CTTAAG-5'

24. Competent host is essential for biotechnology experiment. Since DNA is a hydrophilic molecule, it cannot pass through membranes, so the bacterial cells must be made capable to take up DNA i.e., made competent.

This can be achieved by:

(i) Treatment of DNA with divalent cation of CaCl_2 or rubidium chloride Treating them with a specific concentration of a divalent cation, increases the efficiency with which DNA enters the bacterium through pores in its cell wall.

(ii) Heat shock treatment of DNA: Recombinant DNA (rDNA) can then be forced into such cells by incubating the cells with recombinant DNA on ice, followed by placing them briefly at 42°C (heat shock) and then putting them back on ice. This enables the bacteria to take up the recombinant DNA.

25.

a)
i) Anode \rightarrow (S)
ii) Smallest/lightest DNA \rightarrow (R)
iii) Agarose gel \rightarrow (T)

b) The process of extracting out DNA by cutting Agarose gel and isolating DNA from it is called elution.
 \rightarrow Elution is important to extract & isolate DNA in purest form as they are separated using electric field.

[Topper's Answer, 2022]



26. Several non-viral and non-vector methods are used to transfer genes or alien DNA into a plant cell. One such method suitable for plants is the biolistic or gene gun method. In this method, cells are bombarded with high velocity microparticles of gold or tungsten coated with DNA. Although this method is suitable for plants yet this technique is also used to insert genes into animals that promote tissue repair into cells near wounds. This method failed to make an impression in treatment of genetic disorder but made great impact in the field of vaccine development.

27. Ti plasmid and E. coli are the natural commonly used cloning vectors. Ti plasmid is present in *Agrobacterium tumefaciens*. This plasmid present in bacteria is responsible for causing tumor in plants. T-DNA is modified by removing the tumor genes and introducing a gene of interest. E. coli is used as a vector with a small piece of foreign gene introduced in it which can be useful for cloning. Both of these vectors should have

(i) Presence of origin of replication (Ori): Ori is a site in plasmid where initiation of replication occurs without these sites the process of replication cannot be carried out without ori.

(ii) Selection of transformants from selectable marker: The vectors should possess antibiotic resistant gene to select transformants from non-transformants after the formation of recombinant DNA.

28. (a) EcoRI is a type II restriction endonuclease enzyme which recognizes the base sequence at palindrome sites in DNA duplex and cut its strand. It recognises the base sequence GAATTC in DNA duplex and cut its strands between G and A as shown below:

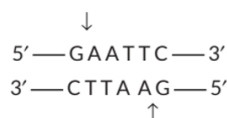

The product obtained is as follows:

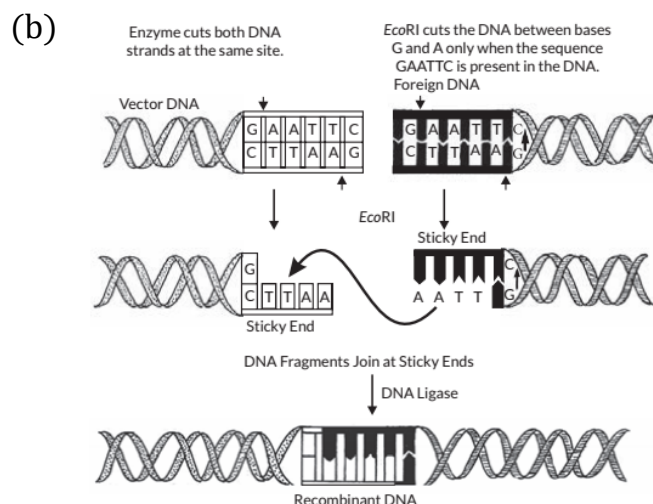
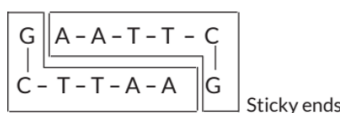

(c) Enzymes which help in formation of recombinant DNA are:

Restriction endonucleases and ligase enzyme.

29. (a) In gel electrophoresis, DNA molecules migrate in the direction of electrode bearing opposite charge on the basis of size. The smaller the fragment, the farther it moves.

(b) The most commonly used medium or matrix is agarose which is a polysaccharide extracted from sea weeds.

(c) The separated DNA fragments can be seen only after staining the DNA with a compound known as ethidium bromide followed by exposure to UV radiations as bright orange-coloured bands.

30. (a) pBR322 is the first artificial cloning vector constructed in 1977 by Boliver and Rodriguez.

(b) 'rop' codes for the proteins involved in the replication of the plasmid.

(c) amp^R (ampicillin resistance) and tet^R (tetracycline resistance) are two resistance genes which are useful for selectable markers. The presence of restriction sites within the markers tet^R and amp^R permits an easy selection for cells transformed.

31. The restriction endonuclease enzyme EcoRI inspects the length of a DNA sequence. Once it recognises specific sequence, it binds to the DNA and cuts each of the two strands of the double helix at specific points in their sugar-phosphate backbones. Each restriction endonuclease recognises a specific palindromic (a sequence of base pairs that reads same on the two strands when orientation of reading is kept the same) nucleotide sequence in the DNA. EcoRI cuts the strands of DNA a little away from the centre of the palindromic site, but between the same two bases on the opposite strands. This leaves single stranded portions at the ends. There are overhanging stretches called sticky ends on each strand. DNA fragments join at sticky ends by the action of the enzyme DNA ligase. This leads to the formation of recombinant DNA composed of DNA from different sources/genomes.

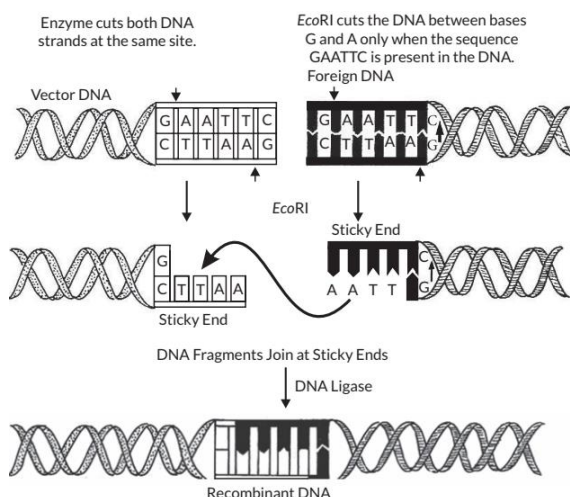

32. Some genes called selectable markers help in selecting those host cells which contain the vectors and eliminating the non-transformants. β -galactosidase is an alternative selectable marker developed to differentiate recombinants and non-recombinants on the basis of their ability to produce colour in the presence of a chromogenic substance. A recombinant DNA is inserted in the coding sequence of an enzyme β -galactosidase. This causes inactivation of the enzyme which is called insertional inactivation. If the plasmid in the bacterium does not have an insert, the presence of a chromogenic substrate gives blue coloured colonies. Presence of insert results into insertional inactivation of the β -galactosidase and, therefore, the colonies do not produce any colour, these colonies are marked as recombinant colonies. β -galactosidase is a preferred selectable marker to antibiotic resistance genes because due to inactivation of antibiotics, selection of recombinants becomes burdensome process as it requires simultaneous plating on two plates having different antibiotics. But by using β -galactosidase as selectable marker, we can select recombinants and non-recombinants on a single plate.

33. (a) Restriction enzymes: These enzymes belong to the class of enzymes nucleases which breaks nucleic acids by cleaving their phosphodiester bonds. They are of two types: exonucleases and endonucleases. Exonucleases remove nucleotides from the ends of DNA. The cutting of DNA at specific locations within the DNA strand is possible with the help of 'molecular scissors' called restriction endonuclease. Restriction endonucleases make highly specific internal cuts in the DNA strand. These enzymes recognise palindromic sites within the DNA duplex and cut its strands by hydrolysing the phosphodiester bonds. Their single stranded free ends are called sticky ends which can be joined end to end by DNA ligases. Restriction endonucleases serve as a tool for cutting DNA molecules at predetermined sites, which is the basic requirement for gene cloning or recombinant DNA technology. For example, restriction endonuclease EcoRI found in the colon bacteria *Escherichia coli*, recognises the base sequence GAATTC in DNA duplex and cuts its strands between G and A as shown:

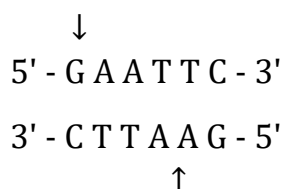

(b) Plasmids : They are extra-chromosomal, self-replicating, usually circular, double-stranded DNA molecules that are found naturally in many bacteria and also, in some yeast. Although plasmids are usually not essential for normal cell growth and division, yet they often confer some traits on the host organism, for example, resistance to certain antibiotics or toxins that can be a selective advantage under certain conditions. The plasmid molecules may be present as

single copy or in multiple copies (500-700) inside the host organism. These naturally occurring plasmids have been modified to serve as vectors in the laboratory. Plasmids are essential in biotechnological experiment as they help in transferring a segment of foreign DNA (gene of interest) into suitable host. Ti plasmid is widely used vector for cloning genes in plants. The most widely used, versatile, easily manipulated vector, pBR322 is an ideal plasmid vector. It was the first artificially cloned vector and is used widely in gene cloning experiments.

34. (a) The cutting of DNA at specific locations is possible with the help of 'molecular scissors' called restriction endonuclease. Restriction endonucleases make highly specific internal cuts in the DNA strand. These enzymes recognise palindromic sites within the DNA duplex and cut its strands. Their single stranded free ends are called sticky ends which can be joined end to end by DNA ligases.

(b) DNA fragments can be separated by gel electrophoresis. In this process, DNA strands (negatively charged) are separated by forcing them to move towards the anode under an electric field through a medium/ matrix. Now-a-days the most commonly used matrix is agarose gel which is a natural polymer extracted from sea weeds. The DNA fragments separate (resolve) according to their size through sieving effect provided by the agarose gel. Hence, the smaller the fragment size the farther it moves. The separated DNA fragments can be visualised only after staining the DNA with a compound known as ethidium bromide followed by exposure to UV radiation.

(c) In pBR322, selectable markers are antibiotic resistance gene that help to identify transformants and eliminate non-transformants. In case of pBR322, there are present two antibiotic resistance genes tetracycline resistance (tet^R) and ampicillin resistance (amp^R).

35. (a) Palindromic nucleotide sequences are base pair sequences that are the same when read forward (left to right) or backward (right to left) from a central axis of symmetry. This special sequence in the DNA is recognised by restriction endonuclease and once restriction endonuclease recognises this specific palindromic sequence, it binds to the DNA and cuts each of the two strands of the double helix at specific points in their sugar phosphate backbone. Restriction enzymes cut the strand of DNA a little away from the centre of the palindrome sites but between the same two bases of the opposite strands. This leaves single stranded unpaired bases at cut ends. These ends with unpaired bases are called sticky ends or cohesive ends. The latter are named so because they form hydrogen bonds with their complementary cut counter parts. The sticky ends facilitate the action of the enzyme DNA ligase.

(b) Restriction endonuclease recognises palindromic sequences in DNA and cuts them. These ends can be joined to form recombinant DNA.



36. (a) Plasmid pBR322 is a most widely used cloning vector. It has two resistance genes ampicillin resistance (amp^R) and tetracycline resistance (tet^R) which are considered useful as selectable markers. Selectable markers help in identifying and eliminating non-transformants and selectively permitting the growth of transformants. Bacterial cells containing recombinant pBR322 will be unable to grow in the presence of ampicillin, but will grow on tetracycline.

(b) β -galactosidase is a preferred selectable marker to antibiotic resistance genes because due to inactivation of antibiotics, selection of recombinants becomes burdensome process as it requires simultaneous plating on two plates having different antibiotics. But by using β -galactosidase as selectable marker, we can select recombinants and non-recombinants on a single plate.

37. (a) Competent host is essential for biotechnology experiment. Since DNA is a hydrophilic molecule, it cannot pass through membranes, so the bacterial cells must be made capable to take up DNA i.e., made competent.

This can be achieved by treatment of DNA with divalent cation of CaCl_2 . Treating them with a specific concentration of a divalent cation, increases the efficiency with which DNA enters the bacterium through pores in its cell wall.

(b) Biolistic gun helps in the process of gene transfer into the host cell without using a vector. In biolistic method or gene gun method, tungsten or gold particles, coated with foreign DNA are bombarded into target cells at a very high velocity. This method is suitable for plants, but is also used to insert genes into animal that promote tissue repair into cells (particularly cancer of mouth) near wounds. It has made great impact in the field of vaccine development.

38. After the cutting of DNA by restriction enzyme, fragments of DNA are formed. Separation of DNA fragments according to their size or length is done by a technique called agarose gel electrophoresis.

It is a technique of separation of molecules such as DNA, RNA or protein, under the influence of an electrical field, so that they migrate in the direction of electrode bearing the opposite charge, viz., positively charged molecules move towards cathode (-ve electrode) and negatively charged molecules travel towards anode (+ve electrode) through a medium/matrix. Most commonly used matrix is agarose.

DNA fragments separate according to size through the pores of agarose gel. Hence smaller the fragment size, the farther it moves.

The separated DNA fragments can be seen only after staining the DNA with a compound known as ethidium bromide (EtBr) followed by exposure to UV radiation. The fragments are visible as bright orange-coloured bands.



39. (a) Origin of replication (Ori) is a specific sequence of DNA bases which is responsible for initiating replication. It is also responsible for controlling the copy number of the linked DNA.

(b) *rop* in pBR322 encodes for a protein involved in replication of plasmid.

(c) HindIII is restriction site in pBR322. It is the site where HindIII endonuclease make a cut so that a foreign DNA segment can be introduced to this vector.

40. The diagrammatic representation of E.coli cloning vector pBR322 is as follows:

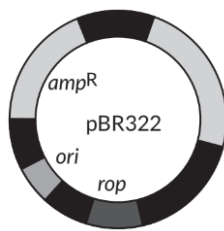

Origin of replication (*ori*): This is a sequence from where replication starts. This sequence is also responsible for controlling the copy number of the linked DNA.

rop : *rop* codes for protein involved in the replication of plasmid.

amp^R : gene for ampicillin resistance which help in selecting transformants.

41. pBR322 was a first artificial cloning vector.

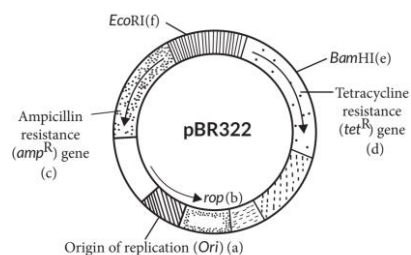

42. (a) Segments of a vector and a foreign DNA with the sequence of nucleotide recognised by EcoRI.

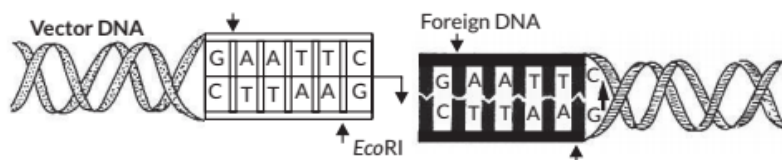

(b) Vector DNA segment and foreign DNA segment after the action of EcoRI.

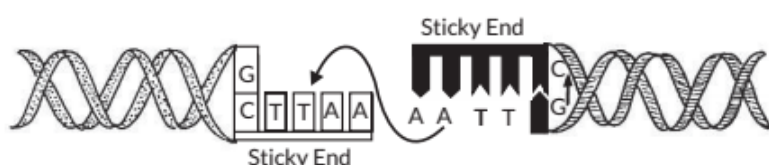

43. (i) (I) EcoRI is a restriction endonuclease enzyme. EcoRI is obtained from bacterium *Escherichia coli* RY13. The capital letter E comes from genus *Escherichia*. The letter co are from species *coli*. The letter R is from RY13 (strain). The roman number I indicates that it was the first enzyme isolated from bacterium *E.coli* RY13.

(II) EcoRI is a restriction endonuclease enzyme. It recognises base sequences 5'-GAATTC-3' in DNA duplex 3'-CTTAAG-5' and cuts each of the two strands between G and A.

(ii) The protruding and hanging stretches of DNA produced by restriction enzyme is called sticky ends.

Role: They formed hydrogen-bonds with their complementary counter parts and facilitate the action of DNA ligase enzyme to join the foreign and vector DNA strands.

44. (i) Plasmid have the ability to replicate within bacterial cells independent of the control of chromosomal DNA and have high copy number, therefore any alien DNA ligated to it, also multiplies to equal the copy number of plasmids. So, it is used as a vector in gene cloning experiments and thus considered as an important tool in biotechnology. Plasmids can be isolated from bacterium (*Escherichia coli*) and yeast (*Saccharomyces cerevisiae*).

(ii) Ori sites are the origin of replication sites which control replication of the DNA in which they are present. Cloning of a vector containing rDNA requires its multiplication to produce large number of copies and ori is essential for it. Selectable marker helps in identifying and eliminating non transformants and selectively permitting the growth of the transformants. Hence, they are considered as essential property in a cloning vector.

(iii) Restriction nucleases act as molecular scissors or chemical scalpels. Each restriction endonuclease functions by 'inspecting' the length of a DNA sequence. Once it finds its specific recognition sequence, it will bind to the DNA and cut each of the two strands of the double helix at specific points in their sugar-phosphate backbones. Each restriction endonuclease recognises a specific palindromic nucleotide sequence in the DNA.

45. (i) EcoRI is a type II restriction endonuclease enzyme which recognises the base sequence at palindrome sites in DNA duplex and cut its strand. It recognises the base sequence GAATTC in DNA duplex and cut its strands between G and A as shown below:

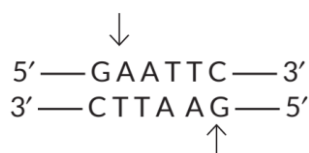

The product obtained is as follows:

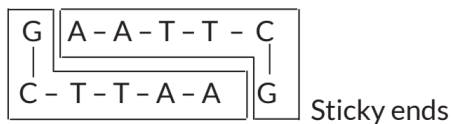

(ii) In gel electrophoresis, DNA molecules migrate in the direction of electrode bearing opposite charge on the basis of size. Smaller the fragment, the farther it moves.

46. (i) 'EcoRI', 'BamHI' and 'Hind III' are type II restriction enzymes. They are used in recombinant DNA technology. They recognise specific sites within the DNA and cut these sites.

(ii) Plasmid pBR322 has two resistance gene - ampicillin resistance (amp^R) and tetracycline resistance (tet^R) which are considered useful for selectable markers. The presence of restriction sites within the markers tet^R and amp^R permits an easy selection for recombinant and non-recombinant cells.

(iii) The plasmid and bacteriophages are efficient cloning vectors as they have ability to replicate within bacterial cells independent of the control of chromosomal DNA.

(iv) Biotechnologists always insert 'ori' gene in their engineered cloning vector because ori is the sequence of DNA bases which is responsible for initiating replication. It is also responsible for controlling the copy number of the linked DNA.

(v) The experiment will not be successful if the alien DNA is ligated at Hind III restriction site because there is no selectable marker at that site.

47. (i) E.coli is the host of this cloning vector pBR322.

(ii) 'W' is 'rop'. Rop codes for the proteins involved in the replication of the plasmid. 'U' represents 'ori' or the origin of replication. This is the sequence from where the replication starts and any piece of DNA when linked to this sequence can be made to replicate within the host cells.

(iii) The enzyme EcoRI (Z) cuts the DNA between bases G and A only when the sequence GAATTC is present in the DNA.

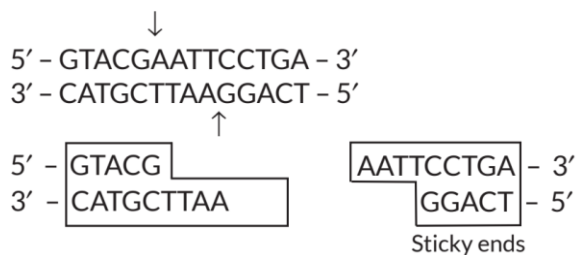

The DNA fragments are joined at sticky ends to form the recombinant DNA.

48. (a) Desirable DNA sequences are cut by the use of enzyme restriction endonuclease. When restriction enzymes cut the strand of DNA a little away from the centre of the palindromic sites, between the same two bases on the opposite strands, it leaves single stranded portions at the ends. These forms overhanging stretches called sticky ends on each strand. They are called sticky as they form hydrogen bonds with their complementary cut counterparts. The stickiness of the ends facilitates the action of the enzyme DNA ligase.

(b) After the cutting of DNA by restriction enzyme, fragments of DNA are formed. Separation of DNA fragments according to their size or length is done by a technique called agarose gel electrophoresis.

It is a technique of separation of molecules such as DNA, RNA or protein, under the influence of an electrical field, so that they migrate in the direction of electrode bearing the opposite charge, viz., positively charged molecules move towards cathode (-ve electrode) and negatively charged molecules travel towards anode (+ve electrode) through a medium/matrix. Most commonly used matrix is agarose.

DNA fragments separate according to size through the pores of agarose gel. Hence the smaller, the fragment size, the farther it moves.

The separated DNA fragments can be seen only after staining the DNA with a compound known as ethidium bromide (EtBr) followed by exposure to UV radiation. The fragments are visible as bright orange-coloured bands.

(c) DNA ligase help to join resultant fragments to the vector DNA molecule. DNA ligases join two individual fragments of double stranded DNA by the formation of phosphodiester bond between them.

49. (b): In the annealing process of PCR, two small chemically synthesised oligonucleotides called primers bind to each of the single stranded template DNA since the sequence of the primers is complementary to the template DNA.

50. None of the options are correct.

Step P is denaturation which occurs at a high temperature of about 94°C to 96°C.

Step Q is annealing where two oligonucleotide primers hybridise to each of the single stranded DNA.

This step occurs at lower temperature.

Step R is extension which occur in the presence of heat stable DNA polymerase.

51. In recombinant DNA technology, enzymes that are used for isolation of DNA from bacterial and fungal cells are lysozyme and chitinase respectively.



52. (a) Bacterium, *Thermus aquaticus* is the source organism of the thermostable DNA polymerase (Taq polymerase) used in PCR.

(b) The advantage of using thermostable DNA polymerase is that they remain active during the high temperature induced denaturation of double stranded DNA. Thus, it is used to synthesise the segment of DNA between the primers (extension) in polymerase chain reaction at high temperature.

53. Taq polymerase is a thermostable DNA polymerase isolated from thermophilic bacterium *Thermus aquaticus*. Taq polymerase is heat stable enzyme and is able to withstand high temperature induced denaturation of DNA during PCR hence it is preferred in PCR reactions.

54. (a) Advantage of stirred tank bioreactors are:

(i) It is well suited for large scale production of micro-organisms under aseptic conditions for a number of days.

(ii) It can be used easily in research laboratories.

(iii) It can be used as an oxygen delivery system.

(iv) It can be used a temperature control system.

(b) After the formation of the product in the bioreactors, it undergoes through some processes before a finished product to be ready for marketing. The processes include separation and purification of products which are collectively called downstream processing.

The product is subjected to quality control testing and kept in suitable preservative.

For example, if drugs are to be manufactured such formulation has to undergo through clinical trials. A proper quality control testing for each product is also needed.

55. (a) RT-PCR stands for Reverse transcriptase - Polymerase Chain Reaction.

(b) The various steps of polymerase chain reaction are:

(i) Denaturation: The target DNA is heated to a high temperature of 92-94°C resulting in the separation of its two strands. Each single strand of the DNA then acts as a template for DNA synthesis.

(ii) Primer annealing: The two oligosaccharide primers hybridise to form each of the single stranded template DNA, since the sequence of the primer is complementary to the 3' end of the template DNA.

(iii) Extension of primer: The taq DNA polymerase synthesises the DNA region between the primers, using dNTPs (deoxynucleoside triphosphate) and Mg^{2+} .



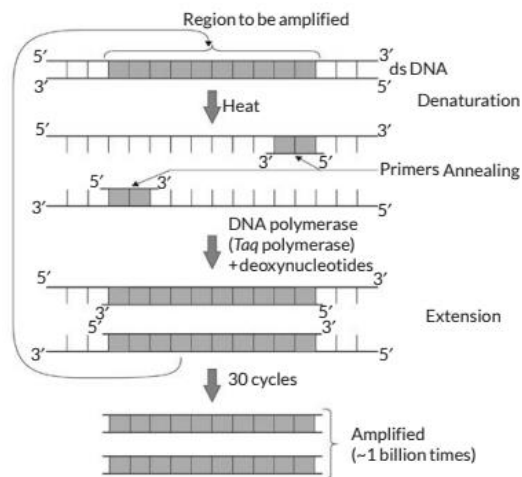

56. A cell free method of amplifying DNA first developed in the mid 1980's which revolutionised the field of biotechnology is the Polymerase chain reaction (PCR). It was invented by. ary Mullis in 1985. PCR is best defined as the DNA replication in vitro.

For the steps of PCR refer to 55 (b):

57. Polymerase chain reaction (PCR) is a technique of synthesising multiple copies of the desired gene (DNA segment) in vitro. The basic requirements of PCR are DNA template, two oligonucleotide primers usually 20 nucleotides long, dNTPs and DNA polymerase which is stable at high temperature (usually Taq polymerase).

Working mechanism of PCR is as follows:

(i) **Denaturation:** The target DNA (DNA segment to be amplified) is heated to high temperature (94°C). Heating results in the separation of two strands of DNA. Each of the two strands of the target DNA now act as template for synthesis of new DNA strand.

(ii) **Annealing** During this step, two oligonucleotide primers hybridise to each of single stranded template DNA in presence of excess of synthetic oligonucleotides.

(iii) **Extension:** During this step, the enzyme DNA polymerase synthesises the DNA segment between the primers. Taq DNA polymerase, isolated from a thermophilic bacterium *Thermus aquaticus*, is used in most of the cases. This step requires presence of deoxynucleotide triphosphates (dNTPs) and Mg^{2+} and occurs at 72°C.

58. (a) DNA is a hydrophilic molecule, so it cannot pass into a host cell through cell membrane. The cell membrane consists of lipid bilayers that are generally impermeable to hydrophilic molecules.

(b) DNA is intertwined with proteins like histones and RNA. To obtain purified DNA, proteases are added during isolation of DNA which convert proteins into amino acids. The purified DNA finally precipitates out after the addition of chilled ethanol.

(c) In order to link the alien DNA, the vector needs to have very few, preferably single recognition sites for the commonly used restriction enzymes. Presence of more than one recognition sites within the vector will generate several fragments, which will complicate the gene cloning process.

59. (a) The most commonly used bioreactor is stirred-tank bioreactor. These bioreactors are used for large scale production of biological products.

(b) Bioreactor consists of a large stainless-steel vessel with a capacity of upto $500,000 \text{ dm}^3$ around which there is a jacket of circulatory water used to control the temperature within the bioreactor.

An agitator with a series of flat blades ensures thorough mixing of contents rotated with the help of a motor so that nutrients come in close with the micro-organisms. It also prevents setting out of the cells at the bottom.

Bioreactor also has an adequate arrangement for aeration, temperature and pH control. Sparger is a porous ring at the bottom of the tank which aerates the culture. There are a number of ports through which materials can be introduced or withdrawn. A harvest line at the base of the tank extracts the culture medium and microbial products. To detect and regulate the pH and temperature changes, tank is fitted with certain probes.

60. In the process of PCR (polymerase chain reaction), the role of high temperature, primer and *Thermus aquaticus* is as follows:

(a) High temperature: During high temperature denaturation step takes place. In this step, the target DNA is heated to a high temperature (94° to 96°C) resulting in the separation of two strands.

(b) Primers: During annealing, the two oligonucleotide primers anneal to each of the ssDNA template since the sequence of the primers is complementary to the 3' ends of the template DNA. Presence of primer is important for polymerisation to take place. Temperature (40°C - 60°C) is kept low depending on the length and sequence of primers.

(c) *Thermus aquaticus*: During the final step called polymerisation, the enzyme DNA polymerase synthesises the DNA segment between the primers. Usually, Taq DNA polymerase is isolated from a thermophilic bacterium *Thermus aquaticus*. This helps in synthesis of DNA region between the primers, using deoxynucleoside triphosphates and Mg^{2+} .



61. (a) Small volume cultures cannot give large quantities of the product. So, the large-scale production (100-1000 litres) of the products is carried out in bioreactors.

Bioreactors are vessels in which raw materials are biologically converted into specific products by microbes, plants and animal cells and their enzymes.

It provides optimal growth conditions such as temperature, pH, substrate, vitamins, oxygen and salts. This type of culturing method produces a larger biomass to get higher yields of desired proteins.

(b) The most commonly used bioreactor is stirred-tank bioreactor. It consists of a large stainless-steel vessel with a capacity of upto $500,000 \text{ dm}^3$ around which there is a jacket of circulatory water used to control the temperature within the bioreactor.

An agitator with a series of flat blades ensures thorough mixing of contents rotated with the help of a motor so that nutrients come in close with the microorganisms. It also prevents setting out of the cells at the bottom.

Bioreactor also has an adequate arrangement for aeration, temperature and pH control. Sparger is a porous ring at the bottom of the tank which aerates the culture. There are a number of ports through which materials can be introduced or withdrawn. A harvest line at the base of the tank extracts the culture medium and microbial products.

To detect and regulate the pH and temperature changes, tank is fitted with certain probes.

62. Recombinant DNA technology can be used to obtain foreign-gene-products. It involves following steps:

- (i) Isolation of genetic material (DNA) using enzymes.
- (ii) Identification and cutting of DNA from specific location using restriction enzymes and separating the fragments of DNA using gel electrophoresis to obtain gene of interest.
- (iii) Amplification of gene of interest using PCR.
- (iv) Adding or ligation of gene of interest into suitable vector using ligase enzymes. This produces a recombinant DNA molecule.
- (v) Insertion of recombinant DNA into the host cell or organism.
- (vi) Selection of recombinants from non-recombinants cells.
- (vii) Culturing recombinant cell under suitable conditions and obtaining the desired foreign-gene-product.



63. The given steps shows the sequence of PCR:

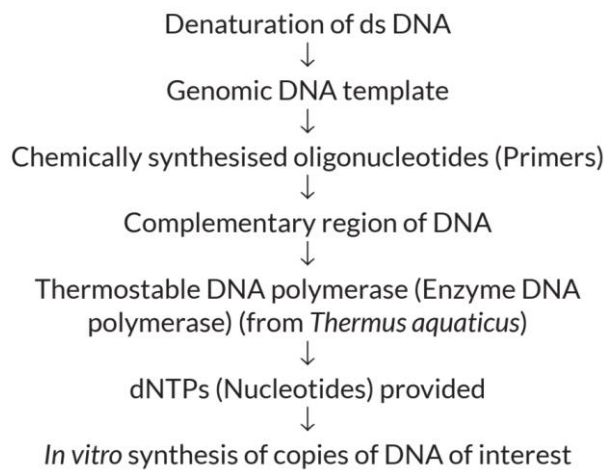

64. Flowchart representing the formation of recombinant DNA by the action of restriction endonuclease enzyme *EcoRI* is as follows:

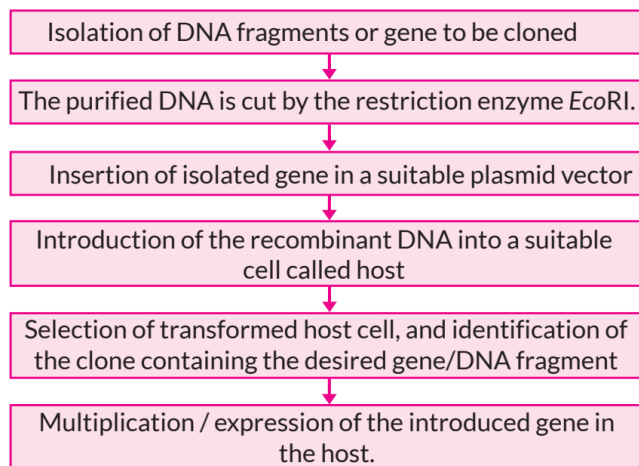

65. (a) Polymerase chain reaction (PCR) is a technique of synthesising multiple copies of the desired gene (DNA segment) in vitro. The three steps involved in PCR are:

- (i) Denaturation (ii) Annealing (iii) Extension.

(b) Taq polymerase is a thermostable DNA polymerase isolated from thermophilic bacterium *Thermus aquaticus*. Taq polymerase is heat stable enzyme and is able to withstand high temperature induced denaturation of DNA during PCR hence it is preferred in PCR reactions.

66. A bioreactor is a device in which a substrate of low value is utilised by living cells or enzymes to generate a product of higher value. These are used for food processing, fermentation, waste treatment, etc.

The most commonly used bioreactors are of stirring type. Stirring type bioreactors may be (i) Simple stirred tank bioreactor and (ii) Sparged stirred - tank bioreactor. Two components of a simple stirred tank bioreactor are cooling jacket and stirrer blades.

67. (a) A bioreactor is a device in which a substrate of low value is utilised by living cells or enzymes to generate a product of higher value. Bioreactors provides optimal growth conditions such as temperature, pH, substrate, vitamins, oxygen and salts. It has an agitator, an oxygen delivery system, a foam controller, a temperature controller, pH controller and sampling ports so that culture can be withdrawn periodically. This type of culturing method produces a larger biomass to get higher yields of desired proteins.

(b) The most commonly used bioreactors are of stirring type. Stirring type bioreactors may be (i) Simple stirred-tank bioreactor and (ii) Sparged stirred-tank bioreactor.

68. (i) Four operational guidelines to achieve optimisation of the bioreactor system are:

- The bioreactor should be designed exclude entrance of contaminating organisms as well as containing the desired organisms.
- The culture volume should be remain constant (ie., no leakage or evaporation).
- The dissolved oxygen level must be maintained above critical levels of aeration and culture agitation for aerobic organisms.
- Environmental parameters like pH, temperature must be controlled and the culture volume must be well mixed.

(ii) Exponential or log phase of the growth is refer in the statement "optimisation of growth and metabolic activity of the cells".

(iii) No, the biological product formed in the bioreactor does not suitable for the intended use immediate. The product has to be subjected through a series of processes, before it is ready for marketing, as a finished product. The process include separation and purification, of products, which are collectively known as downstream processing. A proper quality control testing for each product is needed and if drugs are manufactured has to undergo through clinical trials to avoid harmful effects.

69. (a) Polymerase chain reaction (PCR) is a technique of synthesising multiple copies of the desired gene (DNA segment) in vitro. The basic requirements of PCR are DNA template, two oligonucleotide primers usually 20 nucleotides long, dNTPs and DNA polymerase which is stable at high temperature (usually Taq polymerase).

Working mechanism of PCR is as follows:

(i) Denaturation: The target DNA (DNA segment to be amplified) is heated to high temperature (94°C). Heating results in the separation of two strands of DNA. Each of the two strands of the target DNA now act as template for synthesis of new DNA strand.

(ii) Annealing: During this step, two oligonucleotide primers hybridise to each of single stranded template DNA in presence of excess of synthetic oligonucleotides.

(iii) Extension: During this step, the enzyme DNA polymerase synthesises the DNA segment between the primers. Taq DNA polymerase, isolated from a thermophilic bacterium *Thermus aquaticus*, is used in most of the cases. This step requires presence of deoxynucleotide triphosphates (dNTPs) and Mg^{2+} and occurs at 72°C.

(b) (i) Application of PCR in biotechnology:

- PCR is used in DNA fingerprinting, gene therapy.

(ii) Application of PCR in diagnostics:

- Detection of pathogens

- Diagnosis of specific mutation.

70. (a) Polymerase chain reaction (PCR) is a technique of synthesising multiple copies of the desired gene (DNA segment) in vitro. The basic requirements of PCR are DNA template, two oligonucleotide primers usually 20 nucleotides long, dNTPs and DNA polymerase which is stable at high temperature (usually Taq polymerase).

Working mechanism of PCR is as follows:

(i) Denaturation: The target DNA (DNA segment to be amplified) is heated to high temperature (94°C). Heating results in the separation of two strands of DNA. Each of

the two strands of the target DNA now act as template for synthesis of new DNA strand.

(ii) Annealing: During this step, two oligonucleotide primers hybridise to each of single stranded template DNA in presence of excess of synthetic oligonucleotides.

(iii) Extension : During this step, the enzyme DNA polymerase synthesises the DNA segment between the primers. Taq DNA polymerase, isolated from a thermophilic bacterium *Thermus aquaticus*, is used in most of the cases. This step requires presence of deoxynucleotide triphosphates (dNTPs) and Mg^{2+} and occurs at 72°C.



(b) Applications of PCR:

- (i) Diagnosis of pathogens
- (ii) Diagnosis of specific mutations
- (iii) DNA fingerprinting
- (iv) In prenatal diagnosis
- (v) In gene therapy.

CBSE Sample Questions

1. (b) When foreign DNA is ligated at BamHI site of tetracycline resistance gene in vector pBR322, then recombinant plasmid will lose tetracycline resistance due to insertion of foreign DNA.

2. (a)

3. The commonly used vector for cloning genes into higher organisms is retrovirus or adenoviruses.

4. (a) Sequences which remain same in forward and backward direction are called palindromic sequences. Restriction endonuclease recognises palindromic sequences in DNA and cuts them.

(b) Restriction enzymes can make complementary cut counterparts forming sticky ends for recombination DNA/DNA technology to facilitate ligation of vector and foreign DNA.

5. The recombinant DNA can be forced into the bacterial cell treated with divalent cations and incubating it with recombinant DNA on ice. This is to be followed by placing it briefly at 42°C (heat shock), and then putting it back on ice. This process would enable the bacteria to take up the recombinant DNA.

6. Restriction enzymes cut the strand of DNA a little away from the centre of the palindrome sites, but between the same two bases on the opposite strands. This leaves single stranded portions at the ends. These overhanging stretches on each strand are called sticky ends. They form hydrogen bonds with their complimentary counterparts and facilitate the action of DNA ligase enzyme.

7. (a) No bands will be obtained and all DNA will be seen in the well only, as DNA fragments being negatively charged will not move towards negative end/cathode. DNA being negatively charged will remain stationed at the positive end/anode end of the agar block.

(b) (i) Position of the positive terminal/ anode end/ and the negative terminal/cathode end was inter-changed.

(ii) The fragment with least base pairs will get separated faster and move faster to the anode end.

8. (a) Band III corresponds to 2500 base pairs, and Band IV corresponds to 100bp.

(b) The fragments will resolve according to their size. The shorter sequence fragments would move farthest from well as seen in band IV (100 bp) which is lighter as compared to band III which is heavier being 2500 base pairs. The significance of electrophoresis is to purify the DNA fragments for use in constructing recombinant DNA by joining them with cloning vectors.

9. (a) The main objective of this action is that the two different DNA molecules will have compatible ends to recombine.

(b) Restriction enzyme cuts the DNA of the vector and then ligates the gene of interest into the DNA of the vector.

(c) If the given DNA fragment was cut with BamH1, 2 fragments will be produced in the end with the given polarity.



(d) BamHI site will affect tetracycline antibiotic resistance gene, hence the recombinant plasmids will lose tetracycline resistance due to inactivation of the resistance gene.

Recombinants can be selected from non-recombinants by plating into a medium containing tetracycline, as the recombinants will not grow in the medium because the tetracycline resistance gene is cut.

10. Bioreactors are vessels in which raw materials are biologically converted into specific products such as enzymes using microbial, plant, animal or human cells. A bioreactor provides the optimal conditions for achieving the desired product by providing optimum growth conditions like temperature, pH, substrate, salts, vitamins and oxygen.

11. The extraction of DNA from *Rhizopus* in its purest form can be done by treating with enzymes such as chitinase which will dissolve the cell wall as it is fungus. The RNA can be removed by treatment with ribonuclease whereas proteins can be removed by treatment with protease. Other molecules can be removed by appropriate treatments thereby purifying DNA.

12. A single stranded DNA or RNA is tagged with a radioactive molecule (probe) that allowed to hybridise to its complementary DNA in a clone of cells which followed by detection using autoradiography.

The clone having the mutated gene will hence not appear on the photographic film, because the probe will not have complementarity with the mutated gene. Hence, cancer induced mutation can be detected.

13. The three steps involved in the process of PCR are:

(i) Denaturation The DNA strands are heated at temperature of 94°C and the strands are separated.

(ii) Annealing: The primers anneal to the complementary strands

(iii) Extension: The DNA polymerase facilitates the extension of the strands.

The flow chart represents the series of steps were undertaken for finding the gene of interest using polymerase chain reaction (PCR).

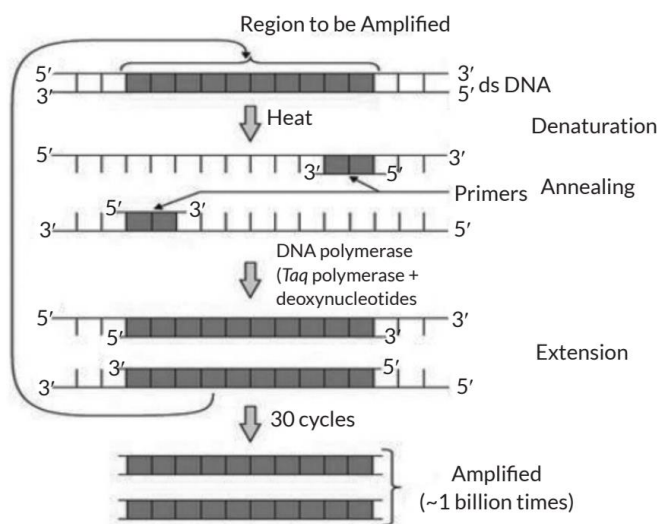

14. (a) Large quantity of bacteria can be easily grown in laboratory. Bacterial cells have plasmids, capable of self-replication, independent of chromosomal DNA.

(b) PCR will not amplify the gene. If the polymerase enzyme functions only at very low temperature, it will not be able to withstand high temperature which is essential for separating/opening/ unwinding/denaturing DNA strand. Thus, subsequent step of extending the primers using the nucleotides provided in the reaction and the genomic DNA as template will not occur.

(c) Positive effect: Oil spills can be treated and the environment becomes cleaner and water becomes more potable and safer for aquatic forms (water birds like sea gulls)

Negative effect: The bacteria can mutate and can harm other organisms. It can conjugate with other non-virulent forms and make them super bugs with detrimental effect or remain unpredictable for a longer duration. It may reduce the dissolved oxygen, leading to mortality of aquatic organisms.